

The Art of Measuring Images:
Albrecht Meydenbauer and the
Invention of the Photographic Survey
— Emma Letizia Jones



1—



2—



3—

In 1868, the little-known project architect and government surveyor Albrecht Meydenbauer (1834–1921) climbed to the top of the Rotes Rathaus in Berlin to shoot the first 360-degree photographic record of the city (Fig.1). In contrast to the idealistic, hyper-real clarity of a more famous painted panorama of Berlin made only 30 years before, Eduard Gaertner's *Panorama von Berlin*, Meydenbauer's photographic panorama is shaky, blurred, unstable.¹ While Gaertner's survey (Fig.2), painted with the aid of a *camera obscura*, is crisp, stiff and hyper-real, Meydenbauer's unsteady photographs betray the limits of his new technology. But it would not be long before Meydenbauer would find a way to overcome these deficiencies, continuing to experiment with film in the scientific recording of the city by using the photographic survey image – or photogram – to document important buildings for posterity. The still existing Meydenbauer archive in Waldstadt, Brandenburg, containing around 20,000 photographs of Berlin and its environs, is an example of one of the earliest uses of architectural photography to document and preserve urban monuments.² However, these photographs were never intended to be simply visual records. Instead, they attest to the potential of the photograph to act not just as a representational device, but also as a generator of a newly projected order in the real spaces of the city. In short, Meydenbauer would begin to use photography to realise an ambition that Leon Battista Alberti could have only dreamed of when he first attempted to survey the city of Rome in the 1440s by 'measuring with sight': that of measuring and ordering the world with nothing but a recording device (in Alberti's case, a circular measuring table and compass) and a point of view.³

The idea behind Meydenbauer's development of pioneering photographic technology to survey buildings and map terrains – a process he called *Messbildkunst* ('the art of measuring images') – began with a near-death accident when he was 24 years old (Fig.3), and conducting freelance work for the Prussian Conservator of Monuments, Ferdinand von Quast. While surveying an 11th-century church in the town of Wetzlar in 1858, Meydenbauer decided to forgo the use of scaffolding, finding it cheaper and quicker to hoist himself up and down the side of the building in a timber box hung by ropes typically used for cleaning the high glass windows.

At the end of one measuring session he attempted to step out from the box on to one of the windowsills and slipped, causing the box to slide out from under him. At the last moment, he managed to propel himself through the open window, where his fall was broken by a spiral staircase fixed to the inside of the wall. After regaining consciousness, Meydenbauer, still shaken by the near-fatal experience, began to wonder how a building surveyor could obtain the geometric properties of those inaccessible parts of a monument without putting his life in danger.⁴

In Meydenbauer's day, photography was already being used widely during surveying for documentation purposes, but still played a role subordinate to the act of measuring, which remained a laborious manual exercise. However, to solve problems of accessibility he had encountered at first hand, Meydenbauer had the idea of taking the mathematical principles of projective geometry and applying them not to the construction of pictorial perspectives, but to reversing the perspective view already captured in his photographic images – which he had begun to call photograms.⁵ From these photograms alone, Meydenbauer devised a method for plotting the extent of a building in plan without the need for direct surveying, relying instead on two known systems of spatial interpolation. Both of these methods derived the geometric properties of an object by using a process of restitution from a perspective image; that is, by working 'backwards' from the perspective (in this case the photograph) to the orthographic drawing using the conventions of projective geometry.

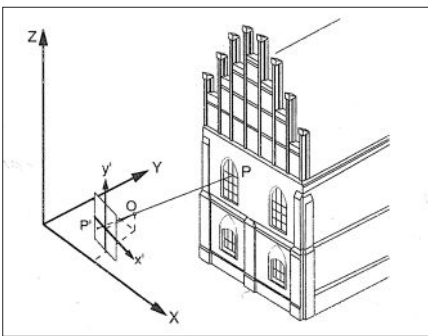

4—

Meydenbauer's idea, in principle, was as old as the invention of perspective itself. Writing around 1480, Leonardo da Vinci had explained that 'perspective is nothing else than seeing a place behind a sheet of glass, smooth and quite transparent, on the surface of which all the things may be marked that are behind this glass. The things approach the point of the eye in pyramids, and these pyramids are intersected on the glass plane.... Among objects of equal size that which is most remote from the eye will look smallest.'⁶ In Meydenbauer's case the photographic surface, rather than the transparent glass, became the intermediary device – one from which an entire set of data could be extrapolated about the object being seen: a modern update to Albrecht Dürer's 16th-century 'Perspective Machine'.⁷ Meydenbauer himself explained this relationship between the object and the picture plane in one of his own diagrams, showing the relationship of the point 'P' on the picture plane to the same point 'P' on the architectural object (Fig.4).



5—

After his accident, around 1860, Meydenbauer began to learn the principles of photography in order to apply his method with accuracy. His first mathematical reconstruction was done from an existing photo of the great pyramid of Giza. Meydenbauer used the photo to calculate the geometrical relations of the structure, and then favourably compared it to values known from existing technical literature. This success was followed by an experiment in drawing the elevation of a house façade from a photograph he took himself. The photograph and the drawing were both exhibited side by side, with a short explanation, at the first International Photographic Exhibition in Berlin, in the summer of 1865. In 1867 he convinced the Prussian Ministry of War and the Ministry of Trade and Public Works to contribute the funds needed for a full-scale surveying experiment in the town of Freyburg an der Unstrut, covering an area of about 2.5km² (which included a particularly detailed photogrammetric survey of the town church). From then on Meydenbauer began to use photogrammetry regularly in his work as a surveyor and construction foreman, and travelled globally to test the method, including to Baalbek (Fig.5). *Messbildkunst* thus came to refer to a method of determining the exact size, shape and position of an object from photographs of it, to the extent that the surveyor

was able to provide drawn surveys without the need for manual measurement at all. Meydenbauer described this process in numerous slides and publications over the second half of the 19th century, culminating in a detailed summary publication in 1912, *Handbuch der Messbildkunst in Anwendung auf Baudenkmäler- und Reise-Aufnahmen* (*Manual of the Art of Measuring as Applied to Architectural Monuments and Travel Recording*).⁸

The origins of perspective restitution

While the photographic tools Meydenbauer invented to make his surveys were relatively new, the principles he employed and described in his publications were not. In applying the method of perspectival restitution to the new technology of photography, Meydenbauer was drawing upon a long investigative history of quantifying the visible, showing that perspective has never been content to settle into a merely illustrative function. One of the earliest examples is Leon Battista Alberti's small publication of 'mathematical games', the *Ludi mathematici*, produced during the 1440s (Fig.6).⁹ This text and accompanying set of diagrams presented a series of exercises for using the eye to measure different elements in the landscape that could not be reached easily by the body (such as, say, the height of a tall tower or the distance of an object across an unbridgeable body of water) by using a combination of triangulation and ratio, and knowing a few key dimensions such as the distance of the eye from the object or from an intermediary measurement tool like a stick. By the early 17th century, these rudimentary games involving the restitution of geometric properties using only the eye had given way to more extensive and complex studies involving perspectival projection systems in drawing. Around 1600, various authors began using the principles of perspective to work out how to reconstruct the space of an already existing painting, expressly so that one would know from what vantage point the perspective was created, and therefore from what position the image should best be appreciated.¹⁰



6—

These investigations eventually culminated in the production of what was possibly the most comprehensive manual on the problem of perspectival restitution available to Meydenbauer in Berlin at the time of his surveying work: the Swiss-Alsatian optician J.H. Lambert's 1759 treatise *Die freye Perspective*, published whilst Lambert was in residence at the Prussian Academy of Sciences in Berlin.¹¹ *Die freye Perspective* was primarily known for being the first practical work on perspective to demonstrate a clear and unified method for constructing objects directly in the picture plane of a drawing (that is, in the perspective image) without the assistance of an intermediary orthographic drawing such as a plan or section. Lambert called these kinds of constructions 'free perspectives', and conceived of them as having their own geometry, which he called 'perspective geometry'.¹²

Lambert's methods for bypassing orthographic drawing in the construction of perspectives were aimed primarily at landscape painters, whose art, growing in popularity, was nonetheless deemed by Lambert to be imprecise, too much reliant on observation alone, and in need of a more mathematically accurate method of composition. However, it turned out to be far more useful as a tool for architectural designers who wanted to accurately test the visual effect of architectural compositions directly on the picture plane. It was used in the teaching of architectural drawing to many later generations of architects and artists in Berlin, contributing to the education of both the young genius architect Friedrich Gilly (1772-1800) and, by the early 19th century, his apprentice Karl Friedrich Schinkel (1781-1841).¹³ When Gilly was invited by the first director of the newly founded Berlin Bauakademie, Johann Albert Eytelwein (1764-1848),

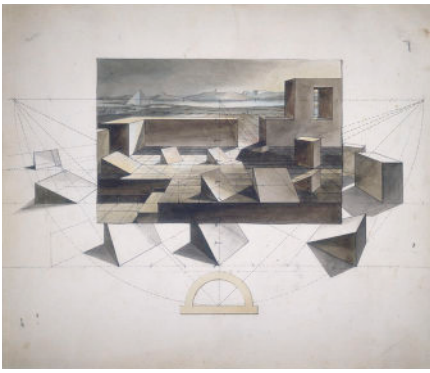

7—

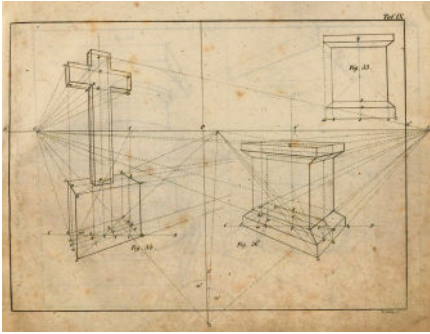

8—

to teach architectural drawing in 1799, he devised a course outline for Berlin's first polytechnical architecture school that included Lambert's manual, and devised a number of teaching aids describing how to use his free perspective method (Fig.7).¹⁴ Eytelwein himself had already published his own *Handbuch der Perspektive* in 1810 based on Lambert's method, as did Johann Erdmann Hummel (1769–1852), painter and professor of perspective, architecture and optics at the Prussian Academy of Arts from 1809, who released his *Die freie Perspektive* in 1825 (Fig.8). Both of these pamphlets were aimed squarely at artists and architects, attempting to translate Lambert's complex steps into a series of visual exercises for students. Schinkel, famously, ushered these pedagogical exercises into the realm of concrete spaces, buildings and spectators when he used corrective perspective to play a wry trick on the audience enjoying Goethe's theatre dedication prologue, which was commissioned for and performed on the occasion of the opening of Schinkel's own Berliner Schauspielhaus on 26 May 1821. Displayed on his design for the stage backdrop curtain – like a portion of a painted Gaertner panorama – was a distant urban image of the very theatre the audience were sitting in. Recently, Kurt Forster was able to calculate, by starting with Schinkel's perspective just as Meydenbauer started with the photograph and worked backwards, from which real viewpoint in the city the image was conceived: it recreates the King's view, from the window of his palace across the city.¹⁵ With an ambiguity by now characteristic of Schinkel's approach to dealing with the political inferences of architecture, this could either be read as a validation of sovereign power over the urban landscape and its citizens, or, more provocatively, as the opposite – a gentle suggestion that the privileged view of the city, as of the action on the theatre stage, is increasingly to be surveyed and shaped by the middle-class metropolitan subject. That Schinkel built this restitution game directly into his stage design reflects his mastery and active application of the Lambertian principles that had infused the drawing education of the Berlin schools 20 years before, when he himself had been a student at the Bauakademie.

Also trained at the Bauakademie and specialising as a *Regierungs-Bauführer* (Government Construction Foreman) in the mid-1850s (he graduated in 1858), Meydenbauer, too, would have been familiar with the 'free perspective' projection regimes outlined and taught by Lambert, Eytelwein and Hummel. In fact, Meydenbauer was the product of an education system that was exceedingly broad, but also allowed its graduates to specialise. For example, not all Bauakademie graduates became architects: many became surveyors, civil servants, engineers (hydraulic, structural, civil), or master builders. But all, no matter their specialisation, were educated in optics, drafting and perspective drawing, in building ornamentation (the orders), in urban and rural architectural design and in the history of architecture; as well as in mathematics, statics, mechanics, building physics, hydraulic engineering, surveying and agriculture. Due to the incredibly broad range of subjects (about 18 in total) that students were required to study, an engineer would receive training in drawing, architectural history, and the art of representation, while an architect, conversely, would be required to study numerous technical subjects.¹⁶ Despite many reforms over the years between its founding and Meydenbauer's own term of study there, this basic principle of cross-disciplinary instruction persisted – the subject of 'architectural invention' (or what we would now term 'design') was introduced for the first time in 1828 and in 1849, *Bauführer* in training were still receiving a full technical education alongside drawing, perspective and optics training, and historically-minded subjects like 'forms of ancient architecture'.¹⁷

Such a model differentiated itself from the architectural education offered at the Berlin Academy of Arts, which, at the time of the Bauakademie's

founding, was strongly aligned with the Oberhofbauamt – the ministry responsible for royal and other ‘magnificent’ buildings. The supervision of *Landbau* – or provincial architecture, agricultural infrastructure and engineering – was the responsibility of the separate Oberbaudepartement, of which J.H. Lambert himself had been an integral part in its earliest days (in 1770 he was designated an honorary member, as an academic expert in the mathematical calculations required for large-scale engineering works).¹⁸ The Bauakademie was originally set up to train and feed students into this more practical department, and many were subsequently deployed as state construction supervisors to provincial regions outside Berlin, ostensibly to raise the general standard of infrastructure and public buildings across the region.¹⁹ Thus, at the Bauakademie, Meydenbauer received training ideal for his career as a surveyor and building project manager working throughout the Prussian provinces, including on vast road and railway constructions.²⁰ However, he was also the recipient of knowledge that would have once been reserved only for the *Oberhofbaumeister*, or first-tier royal architects: such as the ability to judge historic and aesthetic value in architecture according to the established cultural value systems, as well as an ability to understand and practise the art of drawing, particularly the various techniques in perspective construction. This unique combination of skills was the product of broader Prussian educational reforms instigated in the first half of the 19th century, of which the founding of the Bauakademie formed just one part, which aimed to harness the power of the growing bourgeois classes and funnel it directly into the service of the state and the Crown.²¹

Meydenbauer was therefore in many ways a textbook Bauakademie graduate and civil servant, yet he was also a perceptive inventor since for his restitution process he made use of another aspect of Lambert’s theory that was less commonly understood and appropriated. Lambert believed that if one could construct objects directly on the picture plane using perspective geometry, then it followed that those universal properties could be translated back from the picture plane into the reconstruction, or restitution, of an orthographic drawing. Lambert was thus proposing a reversal of the normal conventions of projection, by suggesting that one could begin with the object’s perspectival image in order to end with its geometrical properties, not the other way round – and it is this part of the theory that Meydenbauer was able to make the most effective use of when he applied it to photographs.

The first scholars to establish a clear relation between projective geometry of the kind discussed by Lambert and the processes of photogrammetric surveying were the Germans R. Sturms and Guido Hauck, as late as 1883, but nonetheless before Meydenbauer’s definitive and final publication on the subject.²² In around 1899, too, Sebastian Finsterwalder published a series of papers dealing with perspective restitution in photogrammetry.²³ Thus we can assume that the link was becoming increasingly well understood within the scientific community over the course of Meydenbauer’s activities. Yet there is no other instance, other than Meydenbauer’s, where this link was discussed specifically in the context of surveys of architecture.

A comparison between Lambert’s and Meydenbauer’s methods explains the mathematical basis of Meydenbauer’s speculations, but it also highlights the ways in which Meydenbauer departed from previous discourses. For example, while his methods may be more comprehensive than those of most of the authors that had dealt with the subject before him, Lambert’s interest in perspective restitution was chiefly based, like theirs, on finding the point in space from which an already existing

picture had been constructed. Meydenbauer also deals with this objective, which becomes an essential first step when the surveyor is presented with a photograph he did not take himself (and therefore does not know from where on site the photograph was taken). But he also goes further than Lambert, in that he is not just interested in how a picture is constructed, but also how to reconstruct all the information contained within it.

Meydenbauer's methods

Like Lambert's treatise, Meydenbauer's *Messbildkunst* manual is a largely theoretical work in which mathematical principles are laid out in a series of diagrams, none of which have a great deal to do with real situations. To command the attention of more practically minded listeners, Meydenbauer prepared a series of slides demonstrating his process using real buildings.²⁴ One shows how the general survey plan of a church (the Meißener Dom – Fig.9) was prepared using the correlation of points plotted between three photographs, and indicating from where these photographs were taken. The photographs, noted as 1, 2 and 3 on the plan, are shown alongside it (Figs 10, 11).

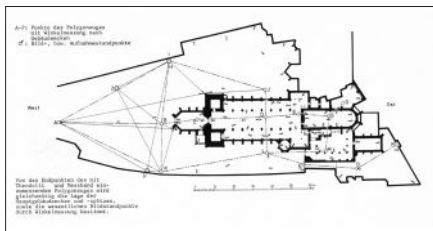

9—

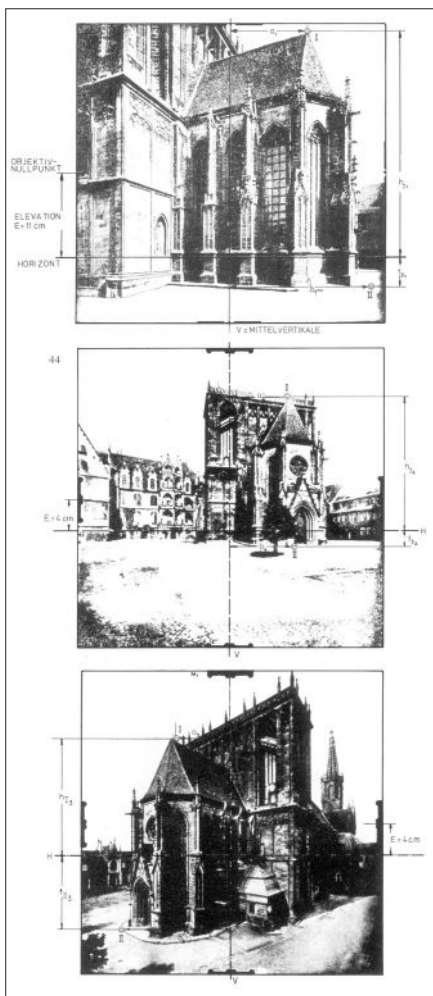

10—

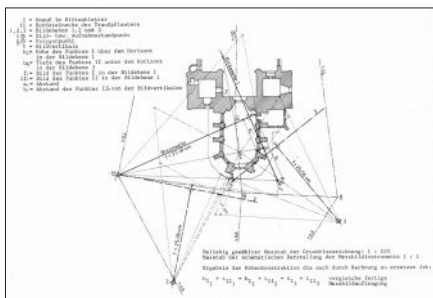

11—

In section 8 of *Die freye Perspective* Lambert gives four conditions that must be known for the restitution of a perspective image, which can be made roughly equivalent to the terms Meydenbauer uses in these slides: the horizon line (plotted on Meydenbauer's photographs and shown as H); the 'eye point' (equivalent to the points on the photographs, I and II, whose properties Meydenbauer wants to determine); the distance of the eye from the picture plane or 'depth of sight' (Meydenbauer's focal length, or *Brennweite*, given by f); and the base line determining height of the eye (or in Meydenbauer's case, the height of the camera horizon line) from the ground.²⁵ To this we could also add the vertical dividing line of the photographs given by Meydenbauer's V, which gives an origin from which various points in the photograph can be measured. If the focal length for each photograph is not known – for example, if the surveyor happened to have been working from a found picture and not one self-taken – various geometrical operations for obtaining its location are detailed in Meydenbauer's *Messbildkunst* manual (see Fig.12, showing the horizon line PN, the vertical centre line and the subsequently obtained focal length OM, found by tracing a semi-circle between P and N). These instructions follow Lambert's process of locating the point from which a picture was made (Fig.13).

To determine the location of, for example, points I and II marked in the photographs and diagrammatic plan of the Meißener Dom in Figs 10 and 11, Meydenbauer plots the rest of the known information in plan to scale. Lines of sight are then drawn through where the points I and II occur on each of the three picture planes, and where these lines come to intersect determines the real location of each of the points. In this way, the position of the point sought can be checked between more than one photograph. Heights can be obtained in a similar way by correlating the distance between two or more fixed points that are represented in all the different photographs, wherever they are taken from. These fixed points relate themselves in height, by ratio, to the horizon line determined in the photograph itself and the scale given on the viewfinder (as in the derived elevation of the Meißener Dom, in Fig.14). With a combination of the position and height of every point, Meydenbauer asserts that a plan and elevation of any existing building can confidently be produced in no greater time than it would take to manually measure and then draw it up. A simpler in-principle diagram detailing this process, showing the relationship between the picture plane and the drawn plan, is given in *Messbildkunst* (Fig.15). There is also a variation on this method – which owes a great deal to Lambert's 'free perspective' instructions – that Meydenbauer demonstrates in the diagram reproduced here as Fig.16.

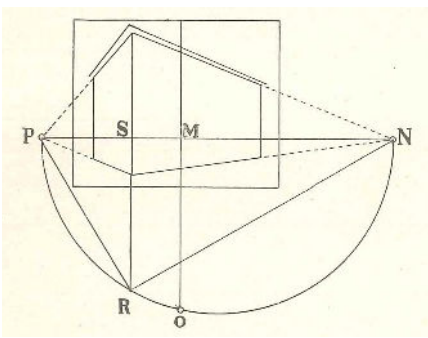

12—

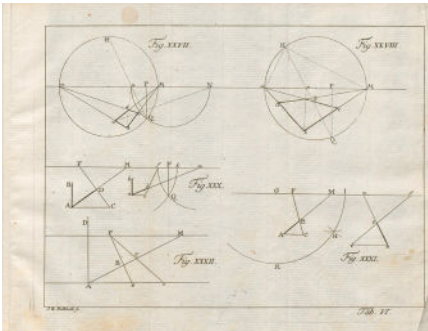

13—

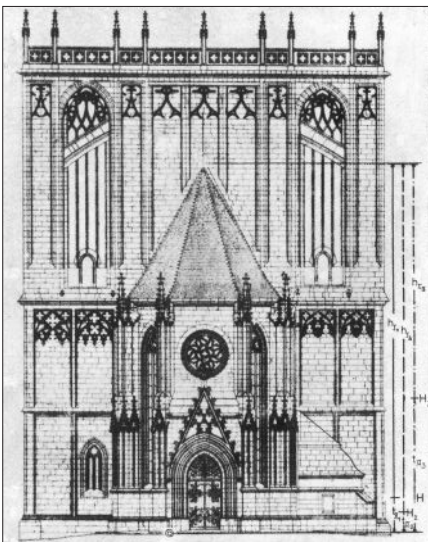

14—

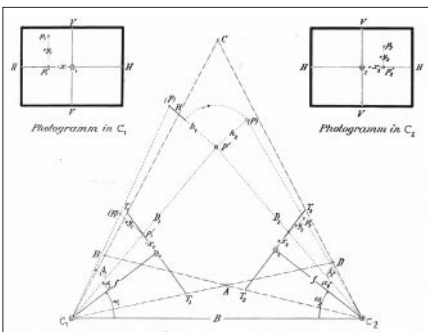

15—

As others besides Meydenbauer were also engaged in researching the photogrammetric possibilities of early photography, we certainly cannot attribute the invention of the entire genre to him. Yet what distinguishes Meydenbauer from his contemporaries, like the Italian geodesist I. Porro or the French Aimé Laussedat who both experimented with the principles of photogrammetry in other forms, was not only Meydenbauer's invention of the term in language but also his application of its principles specifically to the architectural object. Meydenbauer also set himself apart particularly through his invention of the photogrammetric camera (Fig.17) – a device that combined all the features of a commercial camera with a wide-angle lens suitable for capturing urban scenes, along with various other gadgets for correcting angle distortions caused by the lens which might affect the perspectival accuracy of the final image.

The first Meydenbauer cameras, designed in 1864 and then manufactured for sale in a workshop associated with his photographic archive (Fig.18), consisted of a stable frame and a lens at an angle of 105 degrees. The focal length of the lens was 25cm, and a fixed aperture (1:77) was used. The plate size was a square 30 x 30cm, and later, 40 x 40cm for more detailed and accurate images. The camera could be rotated horizontally about its axis by means of a spirit level, and a rotating table on the tripod controlled to a high level of accuracy the camera's vertical and horizontal position. It also contained a viewfinder enclosing the image in a mechanical frame, with a measured scale beside it for adjusting the vertical position of the lens (lens displacement). This helped to locate accurately the horizon line (H) necessary for the later restitution process as well as various other heights on the building by ratio (see Fig.19). The camera parts, in comparison to earlier methods of mounting telescopes and cameras, were located down low on the tripod, as in the example on the far right of Fig.20, for added stability. Meydenbauer continued to develop different iterations of these cameras as the technology improved – such as the one shown in Fig.17, developed after 1890 with an image area of 20 x 20cm, mainly to allow easier portability for photographing on difficult terrains. All the pictures taken using one of Meydenbauer's *Messbild* cameras can be said to have been taken 'photogrammetrically', meaning that they use a specific method and have a specific purpose. Often, they are distinguishable not only for their static clarity but also for the angle from which they have been taken: typically, obliquely, at 45 degrees, placing a corner or edge of the monument in the centre of the frame so the vanishing points of the photograph can be clearly identified and plotted for the easiest restitution. These photograms are not just pictorial records, as we might use photographs typically to record buildings in a conservation capacity today. Instead, they form the basis for exact restoration, refurbishment or even reconstruction.

The apparent shape of the city

The fundamentals of photogrammetry that Meydenbauer developed have become the theoretical foundation of an entire field, albeit not necessarily in the sphere of architecture. With the success of his method in its application to architectural monuments, Meydenbauer eventually came to the conclusion that everything that could be photographed was measurable, and also began to photograph natural terrains for mapping purposes.²⁶ He met with limited success because of limitations in technology and lack of institutional support – but it is nonetheless here that *Messbildkunst* coincides most closely with present practices. Today, photogrammetry is still the best-known method worldwide for the production of topographical maps, usually from aerial photographs. For the reconstruction of objects, infra-red 3D scanning is now a preferred method. However, programmes like Autodesk ReMake still work with 2D photographs, automating the same processes Meydenbauer

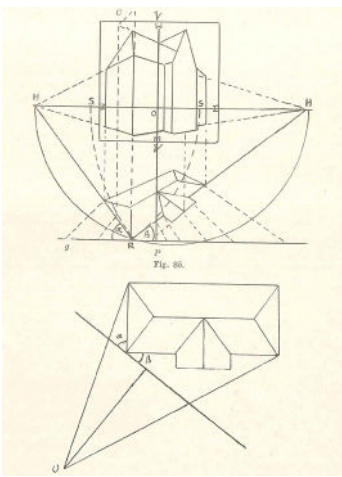

16—

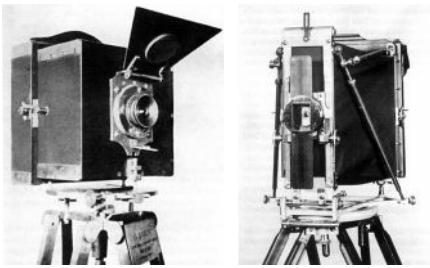

17—



18—

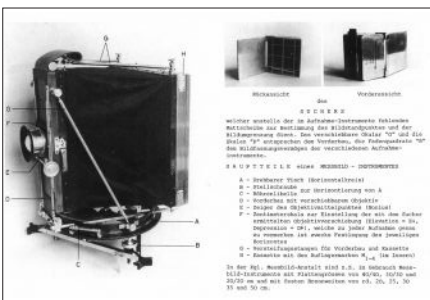

19—

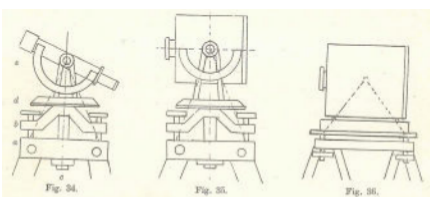

20—

once undertook. One need only input the photos, and the software will correlate similar points in the set using a series of matching algorithms and plot them as points in space. Furthermore, a number of components of Meydenbauer's photogrammetric cameras are still echoed in modern surveying equipment.

On another front, Meydenbauer's photogrammetric archive also represents the early origins of the now indispensable field of *Denkmalpflege* ('monument preservation'), a movement that emerged in the 19th century at the precise moment that the rapid industrial expansion of European cities put the value of such architectural monuments under threat. In Prussia, the discipline of monument preservation took root in tandem with the broader phenomena of German patriotism and cults of remembrance after the Napoleonic wars. It was also accompanied by a flurry of governmental as well as private architectural competitions for the creation of entirely new monuments to the state,²⁷ in response to increasing nationalist sentiment in the population after the wars of liberation and the withdrawal of Napoleon's troops from Berlin in 1813.²⁸ The resurgent popularity of Johann Wolfgang von Goethe's paean to Strasbourg Cathedral, published as part of his 1772 essay 'On German Architecture', stirred a strong cultural sentiment that posited that the roots of a true German identity were to be found in its monuments, and this idea persisted into Meydenbauer's day.²⁹ It was formally cemented when state administrations dedicated solely to providing expert advice to local regions on the preservation of castles, churches, ruins and other buildings assumed to be of cultural significance were set up in Bavaria (1835) and Prussia (1843 – the office held by Meydenbauer's early employer von Quast), and swiftly followed by other German regions including Baden and Württemberg.³⁰ Meydenbauer himself was appointed to just such a post in 1882, when he became Conservator of Monuments in Potsdam.

While art historians often advocated only the preservation of historic monuments, governments, church organisations and private individuals largely supported completion, renovation or reconstruction – often as a means of promoting aspects of their own contributions to the memorial landscape.³¹ During Meydenbauer's tenure aesthetic ideals still promoted visual unity in such reconstructions, which often meant removing later additions to buildings, both inside and out, in order to revert to their so-called original plans. In a famous example, Cologne Cathedral, which was the subject of renovation from the 1840s to the 1880s, was restored to its medieval form and surrounding shops and buildings that had attached themselves to the church over time were cleared away, leaving the building as an autonomous and freestanding monument in the city. The church was thus 'rescued' from complex urban changes over time, evidence of which was eradicated.³² Similarly, when Leo von Klenze – another graduate of the Berlin Bauakademie and trusted architect of the King of Bavaria – was overseeing preservation works in Athens in the 1830s, he did not hesitate to order the removal of Byzantine and Ottoman structures from around classical monuments all over the city (but most notably on the Acropolis) with the goal of restoring them to their 'pure' state.³³ Meydenbauer's activities should be considered in this context as part of a general drive for the 'monumentalisation' of Germany (which was unified in 1871) in the process of its formation as a nation state. But even more than this, his selection of tools for monument recording and preservation both reinforced and simultaneously created these prevalent aesthetic ideals about what a monument should be. That is, photogrammetry privileged the recording of a freestanding building dissociated from its complex urban condition. For the technique to work, it needed to be free of visual obstructions (to allow a series of photographs to be taken from a good distance away), and to be easily recorded in an image without

other structures intervening and potentially disrupting the accuracy of the survey. A monument obscured by complex structures or embedded in a dense urban tissue would not have been a suitable candidate for Meydenbauer's photograms and would have had to be recorded by other methods. It is therefore not easy to understand whether the monuments in Meydenbauer's photograms were chosen for their pre-existing status as such, or whether certain buildings' situational suitability for recording also played a large part in cementing their monumental status.



21—



22—



23—

With the cultural urgency of *Denkmalpflege* as his justification, Meydenbauer founded the Royal Prussian Photogrammetric Institute in 1885 with assistance from the Prussian state. It was located in Schinkel's Bauakademie on the Spree river in Berlin (an iconic building completed in the late 1830s, of which he had also made photographic surveys). Its employees took over 20,000 photographs of buildings in Imperial Berlin up to the early years of the Weimar Republic (Fig.21). In 1921, it was closed because of the economic effects of World War I and integrated with the newly founded Staatliche Bildstelle Berlin (Berlin State Photographic Record). During World War II the photographic negatives were hidden in a mineshaft (although the technical information accompanying them was destroyed in a Berlin air raid), and then after the war taken to Moscow, only to be eventually returned in 1958 (Fig.22). In the tumult of war and of Germany's reconstruction, Meydenbauer's contributions were largely forgotten, his method no longer taught, and the credit for photogrammetric developments passed to figures like Laussedat. Nonetheless, the survival of the Meydenbauer archive proved immensely useful in certain cases for German reconstruction efforts after the war; and when the bombed French Cathedral in Berlin was reconstructed in 1977, it was done largely on the basis of surveys taken from Meydenbauer's 1882 photographs (Fig.23). However, from the time of the archive's integration with the Bildstelle until today, Meydenbauer's photographs, housed at the Brandenburgisches Landesamt für Denkmalpflege in Waldstadt, have largely ceased to act as resources for the surveying of monuments during reconstruction works. Instead, they have become rarefied objects in themselves: photographs preserved for their value as historical and artistic artefacts from before the collapse of the German empire – a value they did not previously possess as part of Meydenbauer's working practice. The photographs in question have undergone a status shift, achieving a certain level of autonomy from their value as useful objects in passing from working tools to works of art: partly because surveying technologies have passed beyond what the photographs can offer, and partly because of the changing status of the photograph as an artistic medium over the course of the 20th century.

Quite apart from practical applications, properly assessing the theoretical ramifications of Meydenbauer's *Messbildkunst* requires a return, again, to Lambert's *Die freye Perspective*. By way of a general introduction to his method, Lambert had begun by explaining that there was often a discrepancy between the way an object appeared before the eye – its 'apparent shape' (*scheinbare Gestalt*), and its complete form and outline, or its 'true shape' (*wahre Gestalt*). 'The art of seeing', he wrote, 'is concerned with the laws by which we distinguish the appearance of things from their true form.... Perspective leaves the true form behind and strives instead to design the apparent form.'³⁴ This distinction, he reasoned, led to two different methods (or 'arts') of representation: perspective and parallel (orthographic) projection. As Lambert explained, perspective projection usually dealt with an object's impact on the viewer, taking the stance that 'what an object appears to be is that which it is *in effect*', and so it was usually concerned primarily with showing an object as it appeared to be, not as it really was.³⁵ While perspective

projection was primarily representational and concerned with describing apparent shape, orthographic projection by contrast attempted to explain the intrinsic geometric properties of an object by devising a means of explaining its true shape, in a specific drawing language (plan, section, elevation) that would avoid the potential errors and omissions of human perception. However, Lambert demonstrably altered the previously prescribed functions of these two respective drawing conventions. Since he could demonstrate – like Meydenbauer after him – that any geometric property of an architectural object could be obtained not only from a plan or a section, as was the convention in architectural drawing, but also directly from a perspective view, he was able to prove that truth and the appearance of it were not so far away from one another after all.

We tend to imagine photography – at least in its earliest incarnations – in a similar way to Lambert’s characterisation of perspective: as a medium that deals in the appearance of things (apparent shape), and as a medium with some inherent degree of representative finality: it captures the world instantaneously, preserving it for posterity. But Meydenbauer’s photographs are not an end product, but rather just one stage in a process of architectural representation that ends with the orthographic drawing instead of beginning with it. In Meydenbauer’s practice, the tool of photography allowed, for the first time in the entire history of architectural representation, the ‘apparent shape’ of the artefact to actually precede the definition of its ‘true shape’ (to use Lambert’s terms). This premise is what makes Meydenbauer’s method so captivating because it represents a system by which a form of representation considered to be both absolute and universal (represented by orthographic projection) develops directly out of one assumed to be contingent and relative (the photograph, taken from the subject’s point of view). Repeating a preoccupation of Berlin architects since the days of Gilly’s instruction at the Bauakademie and precipitated by the particular influence in that city of Lambert’s manual, Meydenbauer’s *Messbildkunst* develops from the ‘point of view’ to the universal view, from the empirical to the absolute, reversing the more common lineage of architectural representation. In doing so, it strips the perspective image of its secondary status in architectural documentation as a representational after-effect, and endows it with an entirely new, determinative function.

That such a powerful mathematical tool had begun to assume an operative function in the realm of architecture is vindicated by a prevailing methodical thread that runs through the work of the many figures, some discussed here, who employed it. Furthermore, the way they used it runs counter to the prevailing wisdom inherited by the architect since the Renaissance through the writings of Alberti: that perspective sketching was to be avoided by architects in the process of designing buildings (and should be left to the painters) because it was too prone to being manipulated in the creation of ‘deceptive appearances’ by which the merits of the design could no longer be judged accurately.³⁶ Yet those who adapted Lambert’s method to their own ends privileged the apparent view rather than mistrusting it, and even gave it a kind of agency to determine the very nature of urban landscapes themselves. This agency is explicit on paper in Gilly’s platonic, freestanding cubes arranged on a ceaseless gridded picture plane, and at built scale in Schinkel’s dynamic institutional monuments, their forms designed first and foremost in perspective, and calculated by restitution to be observed from visually and politically strategic points of view in the open, flat marshland of Berlin. Meydenbauer’s city, correlated through surveying, is also a city of freestanding monuments captured singularly from various angles, redrawn, and thus preserved. One could even imagine all 20,000 of the photographs of churches, town halls and the like that are currently sealed in his archive resurrected

and cobbled together in the manner of Alberti's early map of Rome, in which the city's autonomous urban monuments were plotted in an empty field,³⁷ or a Piranesian Campo Marzio ideal, which resuscitated those same monuments and juxtaposed them together, the spaces between them left undefined.³⁸ Meydenbauer's understanding of *Denkmalpflege* rested on the fact that it was the monuments one preserved or reconstructed in the process of city-making, not the gaps in between.

The one exception to this in Meydenbauer's photographic output is that jumbled urban panorama captured from the Rotes Rathaus, which omits nothing, and therefore distinguishes nothing. In this image, Meydenbauer's Berlin is shown ringed by industry on a colossal scale and inundated by an unprecedented population explosion, while there is no longer any hierarchy to the jumble of rooftops.³⁹ The city's reach is indeterminable, and Schinkel's monuments from 30 years before are barely distinguishable. It is perhaps not too fanciful to suggest that it was the sublime horror of this modern urban scene that Meydenbauer spent the rest of his careful and ordered life devising methods to counteract.

- 1 For a history of this painting see Birgit Verwiebe, 'Erdenstaub und Himmelsdunst: Eduard Gaertner's Panoramen', in *Eduard Gaertner 1801-1877*, ed. Dominik Bartmann (Berlin: Stiftung Stadtmuseum Berlin, 2001), 97-111; *ibid.*, cat. 59, 236-37; and Stephan Oettermann, *The Panorama: History of a Mass Medium*, trans. Deborah Lucas Schneider (New York: Zone Books, 1997), 215-16.
- 2 The architect campaigned tirelessly for the establishment of this archive, which was finally set up in 1885, and is currently in the hands of the Brandenburgisches Landesamt für Denkmalpflege in Waldstadt.
- 3 Alberti's findings, achieved with a compass tool he devised himself and called a 'horizon', are detailed in Leon Battista Alberti, *Descriptio urbis Romæ*, c.1450. Recently translated as *Leon Battista Alberti's Delineation of the City of Rome*, ed. Mario Carpo and Francesco Furlan, trans. Peter Hicks (Tempe, AZ: Arizona Center for Medieval and Renaissance Studies, 2007).
- 4 Meydenbauer's diary entry recounting the event is reproduced in Rudolf Meyer, ed., *Albrecht Meydenbauer: Baukunst in historischen Fotografien* (Leipzig: VEB Fotokinoverlag, 1985), 15-16.
- 5 The term 'photogrammetry' was first introduced in the title of an article 'Die Photogrammetrie', unsigned at the time but later attributed to Meydenbauer, and published in the *Wochenblatt des Architektenvereins zu Berlin* (Berlin Architectural Society - Weekly Journal), 6 December 1867.
- 6 *Oxford World's Classics: Leonardo da Vinci: Notebooks*, ed. Thereza Wells, selected by Irma A. Richter, preface by Martin Kemp (Oxford: Oxford University Press, 2008), 113-14.
- 7 As drawn by Albrecht Dürer, e.g. 'An Artist Draws a Lute', 1525, engraving, 13.6 x 18.2cm. From Dürer, *Underweysung der Messung mit dem Sirckel und Richtscheit*; or 'Perspective Machine', 7.7 x 24.4cm, from the same publication.
- 8 Albrecht Meydenbauer, *Handbuch der Messbildkunst in Anwendung auf Baudenkmäler- und Reise-Aufnahmen* (Berlin: Wilhelm Knapp, 1912).
- 9 These games have been translated into English in *The Mathematical Works of Leon Battista Alberti*, ed. Kim Williams, Lione March, Stephen R. Wassell (Basel: Birkhäuser, 2010), 9-140.
- 10 A key figure in this discourse on perspective restitution was Guidobaldo del Monte, whose book *Perspectivae Libri Sex* (1600) dealt comprehensively with the issue and can therefore be thought of as an early precursor to J.H. Lambert (see note 12). Other mathematicians that later dealt with the issue were Charles Bourgoing (*La perspective affranchie ... sans tracer ny supposer le plan geometral ordinarie*, 1661), and Brook Taylor. See Kirsti Andersen, *The Geometry of an Art: The History of the Mathematical Theory of Perspective from Alberti to Monge* (New York: Springer, 2007), 261.
- 11 J.H. Lambert, *Die freye Perspective* (Zurich: 1759).
- 12 J.H. Lambert, *La Perspective affranchie* (simultaneous French translation of *Die freye Perspective*) (Zurich: 1759), 30; see also Andersen, *op. cit.*, 649.
- 13 Schinkel himself used perspectival restitution methods derived from Lambert and Gilly in many sketch studies for paintings and buildings, and most famously in one of his designs for the stage. Further examples will be discussed in the author's forthcoming monograph on Schinkel's representational methods, titled *Schinkel in Perspective* (Cambridge, MA: MIT Press, 2023).
- 14 Gilly outlines his intention to teach his course in accordance with the 'Lambert system' in a letter to Minister Freiherr von Schrötter, 17 May 1799, in Staatsbibliothek zu Berlin - Preussischer Kulturbesitz, Sammlung Darmstaedter, D 1798 (1): Friedrich Gilly, segments of the letter reproduced in Fritz Neumeyer's introduction to *Friedrich Gilly: Essays on Architecture 1796-1799*, ed. Julia Bloomfield, Thomas F. Reese and Salvatore Settis (Santa Monica, CA: The Getty Center for the History of Art and the Humanities, 1994), 98-99. In the letter Gilly also refers to an album of his own drawings, which he is currently compiling, and intends to use as a complement to already published works from Lambert and others.
- 15 Kurt Forster calculated the perspective and first ventured this hypothesis in 'Only things that stir the imagination: Schinkel as a scenographer' in *Karl Friedrich Schinkel: The Drama of Architecture* (Tübingen: Wasmuth, 1994), 31.
- 16 Christiane Salge, 'Ästhetik versus Wissenschaft. Die Entwurfsausbildung an der Bauakademie in Berlin (um 1800)', in *Wissenschaft Entwerfen* (Leiden, The Netherlands: Brill), 382-414; 394-95.
- 17 Three articles give a broad overview of curricular changes as well as continuities from the Bauakademie's founding until its closure in 1879: Hans Joachim Wefeld, 'Preussens erste Bauschule', in *Von der Bauakademie zur Technischen Universität Berlin - Geschichte und Zukunft*, ed. Technischen Universität Berlin (Berlin; Ernst & Sohn, 2000), 64-74; Erich Konter, 'Die Preussische Bauverwaltung und Ihre Ausbildung von 1770 bis 1850', *ARCH+ 7* (1975), 18-35, 32; Michael Bollé, 'Akademien und Kunstschulen im deutschsprachigen Raum [um 1800]', in *Entwerfen, Architekturausbildung in Europa von Vitruv bis Mitte des 20. Jahrhunderts, Geschichte, Theorie, Praxis*, ed. Ralph Johannes (Hamburg: Junius, 2009), 450-80, 469-70. For a comparison of the list of subjects being taught at the Bauakademie in 1799, as well as those closest to the period in which Meydenbauer was resident at the school, see Wefeld, *op. cit.*, 65, 70-71.
- 18 Konter, *op. cit.*, 19.
- 19 Salge, *op. cit.*, 392-94.
- 20 As part of his studies, Meydenbauer was required to record an old building and submit a set of architectural drawings - he selected the Nicolai Church in Brandenburg. His drawings were seen by Ferdinand von Quast, himself a graduate of the Bauakademie, who appointed Meydenbauer to carry out the fateful surveying work at Wetzlar on the strength of them. Meyer, *op. cit.*, 15.
- 21 Konter, *op. cit.*, 32-33; Bollé, *op. cit.*, 450.
- 22 Guido Hauck, 'Neue Constructionen der Perspective u. Photogrammetrie', in *Journal für reine und angewandte Mathematik*, 95 (1883), Plate 1 (Figs 1-7); and p.31, where Hauck praises Lambert's pioneering achievements in the field. For further details see Frederick J Doyle, 'The Historical Development of Analytical Photogrammetry', *Photogrammetric Engineering*, XXX(2) (1964): 259-65.
- 23 As detailed in Doyle, *op. cit.*, 259-60.
- 24 The whereabouts of the original photographs and slides that are reproduced in Albrecht Grimm's *Photogrammetrie*, and sometimes featured in this article, are unknown. According to Grimm himself, they once belonged to the Meydenbauer collection of the former DDR Messbildstelle, headed by Herr Rudolf Meyer. Grimm was given permission to publish these visual materials in return for obtaining for Herr Meyer a series of film documents from an archive in the USA, documenting crimes committed by the German Wehrmacht in Yugoslavia during the Second World War (Meyer was unable at the time to travel to the west to collect this evidence). The current Meydenbauer archive at the Brandenburg State Monuments Preservation office has no record of the items that were featured in Grimm's publication, and Herr Meyer is now deceased.
- 25 Lambert, *Die freye Perspective*, *op. cit.*, 278.
- 26 Meyer, *op. cit.*, 20.
- 27 An early and notable competition in this vein was that run by the Prussian Academy of Arts in 1796, for a monument to Frederick the Great on Leipziger Platz, Berlin. Friedrich Gilly's famous entry - a classical temple in the round - is well known for, as hearsay goes, inspiring a teenager Karl Friedrich Schinkel to study architecture. For a description of Gilly's project see Adrian von Buttlar, 'Entwurfswege in der Architektur', in Johannes, ed., *op. cit.*, 110-13. For an example of a nationalist competition closer to Meydenbauer's time, Mari Hvattum discusses at length the infamous King Maximilian II of Bavaria's 'competition for a new architectural style' (1850) in chapter 6 of her forthcoming book *Style and Solitude* (Cambridge, MA: MIT Press, 2023).
- 28 For a historical background to these architectural developments, see Annette Dorgerloh, Michael Niedermeier and Horst Bredekamp, eds, *Klassizismus - Gotik: Karl Friedrich Schinkel und die patriotische Baukunst* (Berlin: Deutscher Kunstverlag, 2007), a collection of essays that explores the intersection of state politics, patriotic cultures of remembrance and architectural style in the formation of the German nation in the 19th century.
- 29 The original text appears in Johann Wolfgang von Goethe, 'Von deutscher Baukunst' (1772), in *Goethes Werke, Hamburger Ausgabe*, vol. XII (Hamburg, 1960), 7-15. For a short commentary on Goethe's famous text in English with translations of key passages see Christopher S. Wood, *A History of Art History* (Princeton: Princeton University Press, 2019), 167-75.
- 30 See Winfried Speitkamp, 'Heritage Preservation, Nationalism and the Reconstruction of Historical Monuments in Germany during the Long Nineteenth Century', *Kunstiteaduslikke Uurimus/ Studies on Art and Architecture*, vol.23, no. 3/4 (2014), 37-54, 41, and Speitkamp, 'Kulturpolitik unter dem Einfluß der Französischen Revolution: Die Anfänge der modernen Denkmalpflege in Deutschland', in *Tel Aviver Jahrbuch für deutsche Geschichte*, vol.18 (1989), 129-159. Historic preservation was previously dealt with from within the state building departments.
- 31 Speitkamp, 'Heritage Preservation', *op. cit.*, 42.
- 32 T. Nipperdey, 'Der Kölner Dom als Nationaldenkmal', in *Nachdenken über die deutsche Geschichte. Essays* (Munich: Deutscher Taschenbuch Verlag, 1990), 189-207.
- 33 For a history of the urban planning of Athens in the first half of the 19th century see Eleni Bastea, *The Creation of Modern Athens: Planning the Myth* (Cambridge: Cambridge University Press, 2000).
- 34 Lambert, *Die freye Perspective*, *op. cit.*, 217.
- 35 Lambert, *La Perspective affranchie*, *op. cit.*, 120.
- 36 While the painter, in the striving for effect in the representation of a building, might well be concerned with 'shading and diminishing lines and angles', Alberti believed the architect's proper method was the taking of projections first from the ground plan to form the orthographic elevations of each part of the building. This, he believed, would ensure 'calculated standards'. Furthermore,

these projections were to be rendered in outline, without shading or shadow, to avoid the design being judged by 'deceptive appearances'. See Leon Battista Alberti, *On the Art of Building in Ten Books*, trans. Joseph Rykwert, Neil Leach and Robert Tavernor (Cambridge, MA: MIT Press, 1988), 34.

37 See note 3.

38 Giovanni Battista Piranesi, *Il Campo Marzio dell' Antica Roma, Opera di G.B. Piranesi socio della reale società degli antiquari di Londra* ('The Campus Martius of ancient Rome, the work of G.B. Piranesi, Fellow of the Royal Society of Antiquaries, London'), 1762.

39 Between 1810 and 1840 the city's population more than doubled; and between 1830 and 1847 four major workers' uprisings would occur. By the time Meydenbauer took his photograph Berlin was a fully industrialised city, though long after both Paris and London. On the growth of Berlin and the workers' uprisings, see Marsha Morton, *Johann Erdmann Hummel: a Painter of Biedermeier Berlin*, PhD thesis, New York University (1989), 427–28.

1—



2—



1— Albrecht Meydenbauer, photographic panorama of Berlin, 1868. Brandenburg State Office for the Preservation of Historical Monuments and Archaeological Museum.

2— Eduard Gaertner, *Panorama of Berlin*, 1834. Photo Jörg P. Anders. Property of the House of Hohenzollern, HRH Georg Friedrich Prince of Prussia/SPSG.

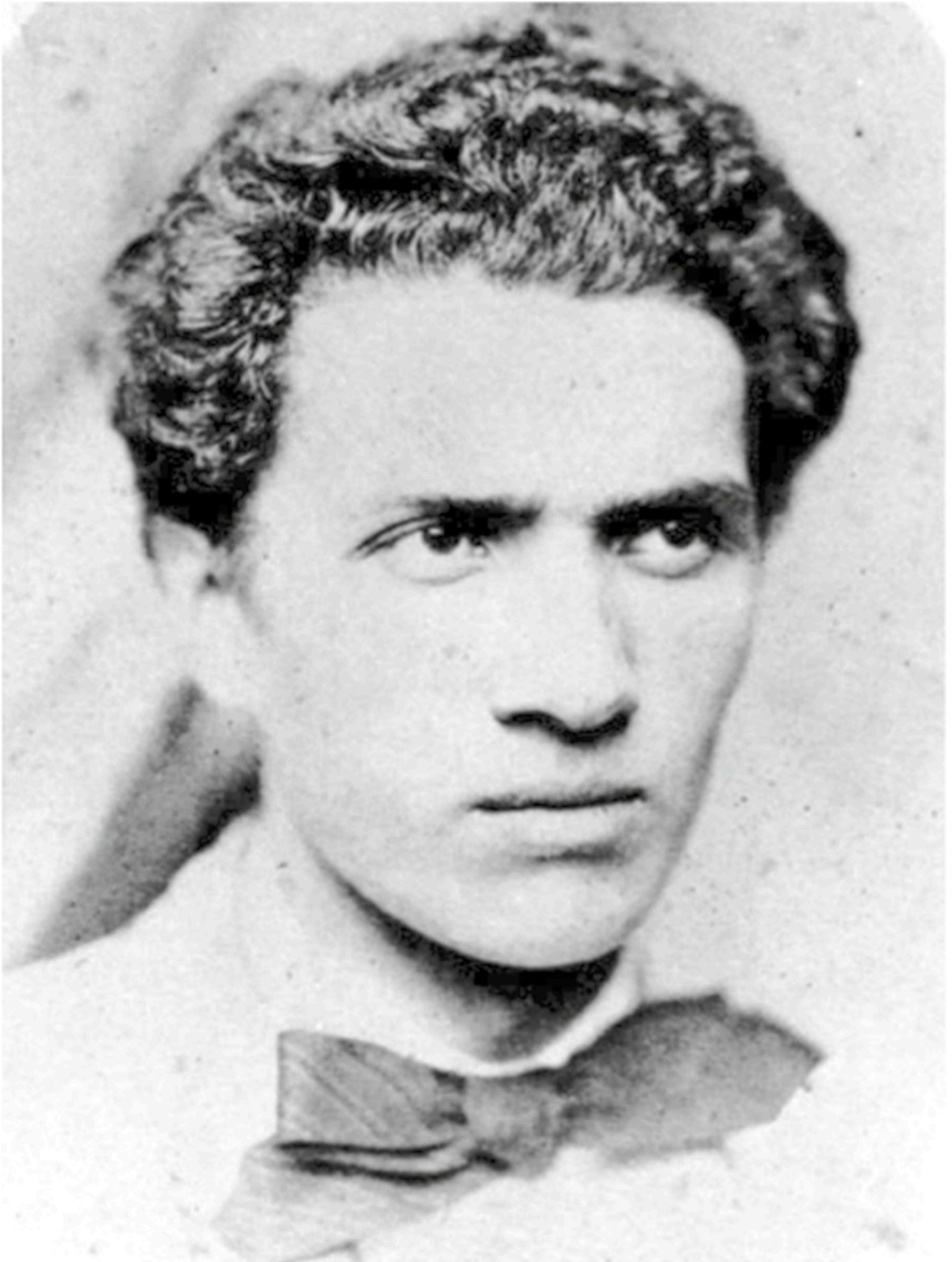

'Der Königliche Bauführer, Albrecht Meydenbauer'. From Albrecht Grimm, *120 Jahre Photogrammetrie in Deutschland*, vol.2 (Munich: R. Oldenbourg Verlag, 1977), 13.

4—

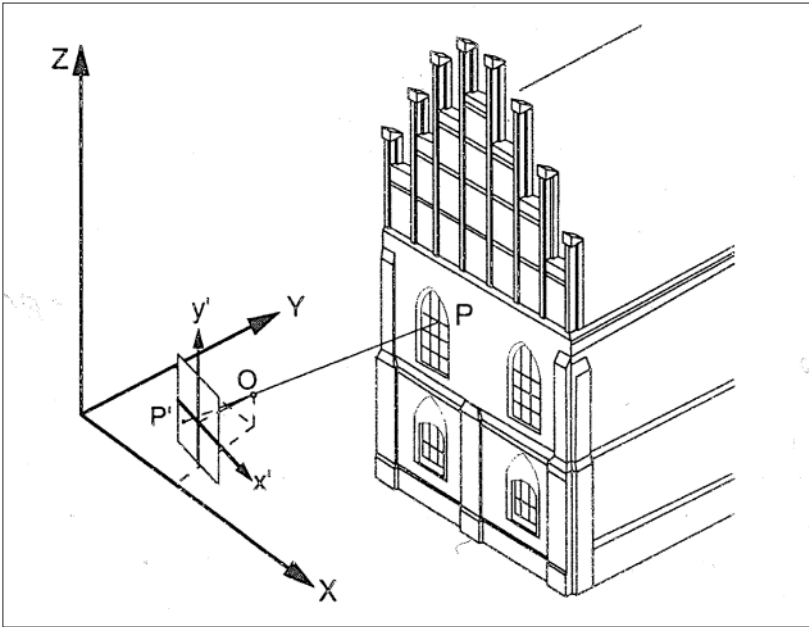

5—



4— Relationship between object and picture plane. From Jörg Albrecht and Albert Wiedemann, eds, *Architekturphotogrammetrie gestern - heute - morgen* (Berlin: TU Berlin, 1997), 71.

5— Meydenbauer with Prof. Schleyer on a survey assignment in Baalbek. From Grimm, *op. cit.*, 48.

Se volete Col veder sendo in capo d'una piazza misurare quanto sia,
 alta quella torre quale sia apud della piazza fate in questo modo
 fighate uno dardo in terra et fighatelo che gli sia a piano fermo et
 poi sostatelo da questo dardo quanto pare a voi o, se o, otto piedi et
 indi mirate alla cima della torre diripando il vostro vedere a mira
 se il diritto del dardo et li dove il vedere vostro batte nel dardo fatelo
 parre un poco di cera e segno et chiamasi questa cera A et firmatelo
 et firmate delli vostri piedi et viso quale mirate la cima della torre
 mirate qui basso il pie di detta torre et quivi simile dare al dardo
 batte il vedere vostro fatelo parre nel dardo un'altra cera et chiamasi
 questa seconda cera B. ultimo mirate qualche luogo in detta torre noto
 a voi aatto a poter facilmente misurar col vostro dardo quando in
 appressate alla torre come fare forse l'arco d'uno o, qualche passo
 o, simil posto in basso et come farate mirando la cima et mirando
 il pie della torre cosi qui fate et ponete un'altra cera nel dardo
 dove batte la vista vostra questa e, cosa nota et chiamasi questa
 terza Cera C. come qui vede la positura

Ortelius

Riccius

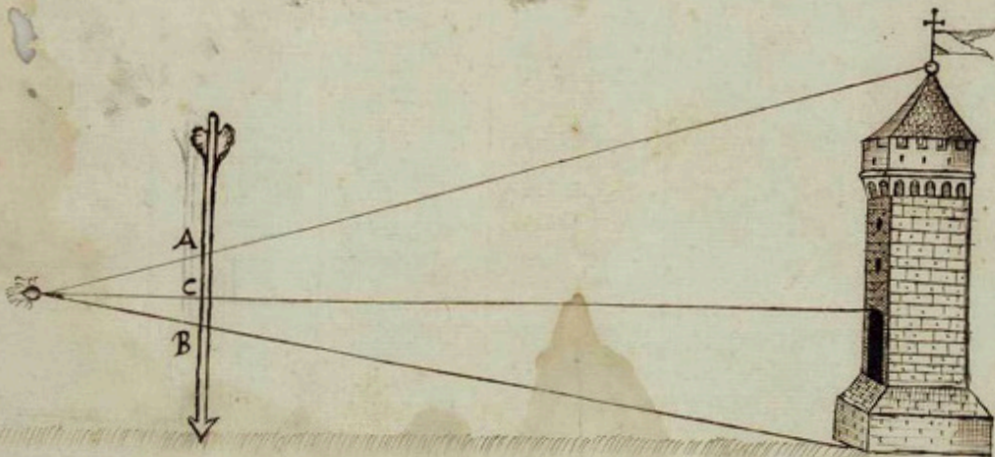

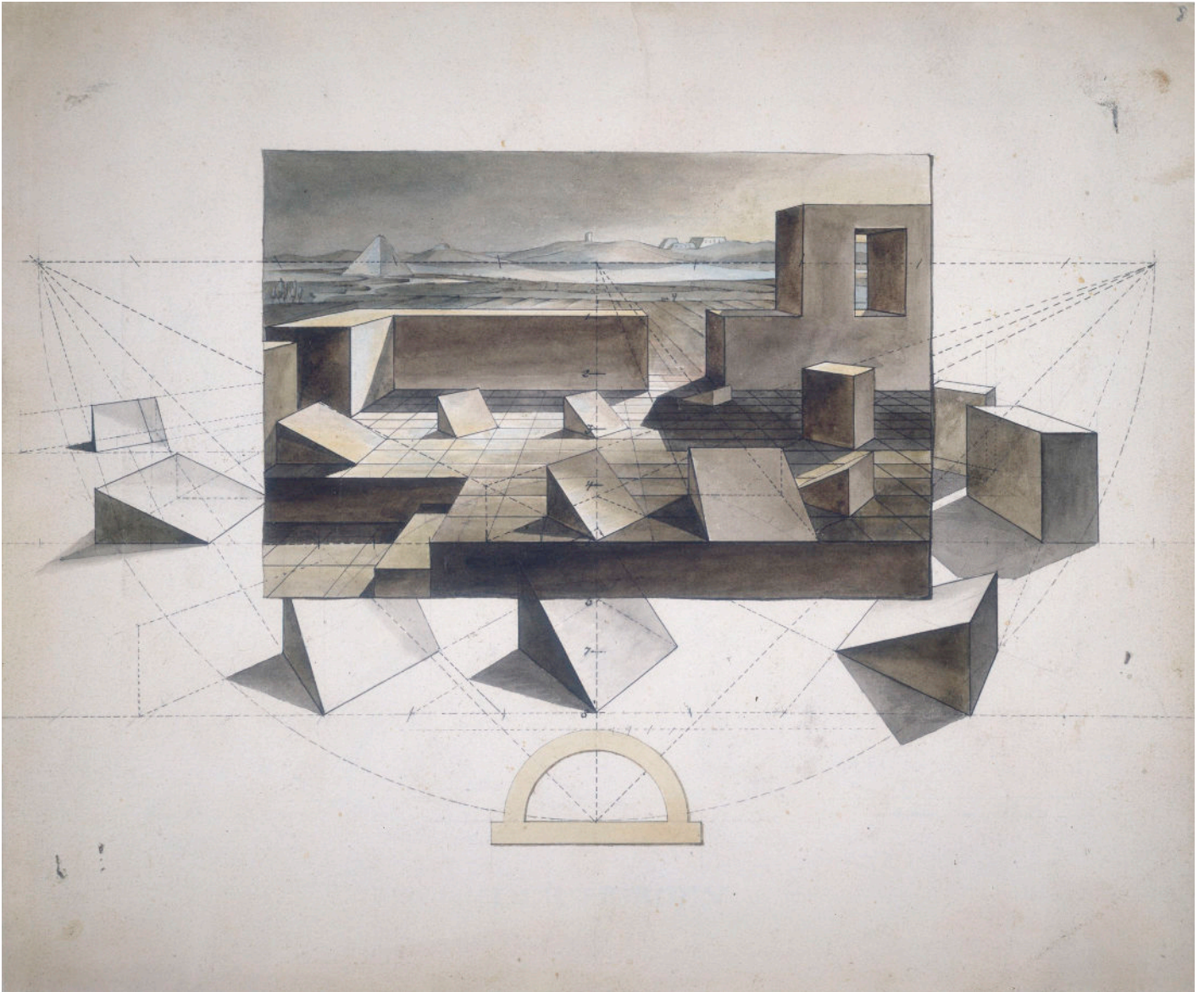

Friedrich Gilly, Perspective study with landscape scenery, before 1800. Photo Dietmar Katz. Berlin State Museums, Kunstbibliothek/bpk, Inv. Hdz 7718.

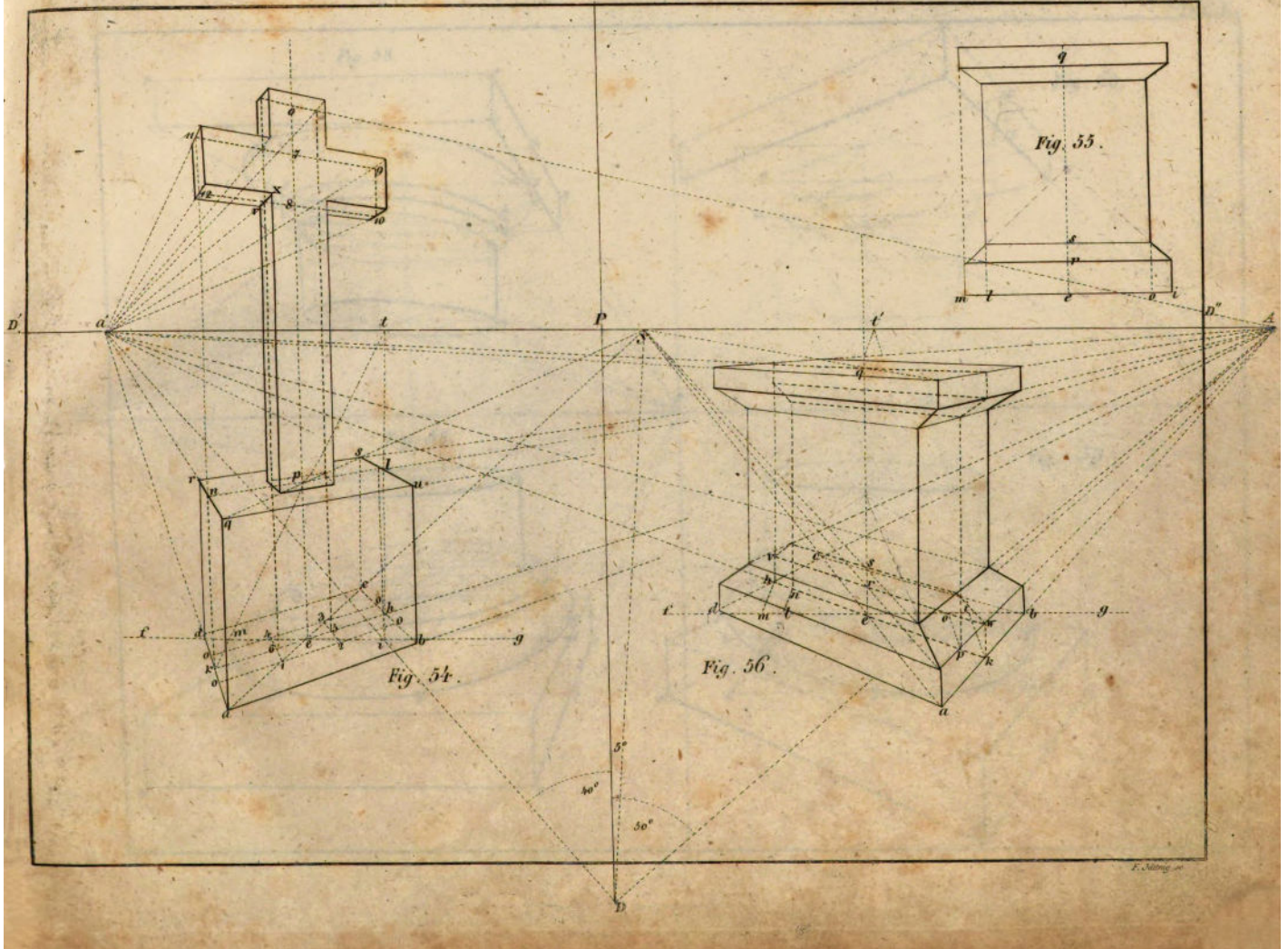

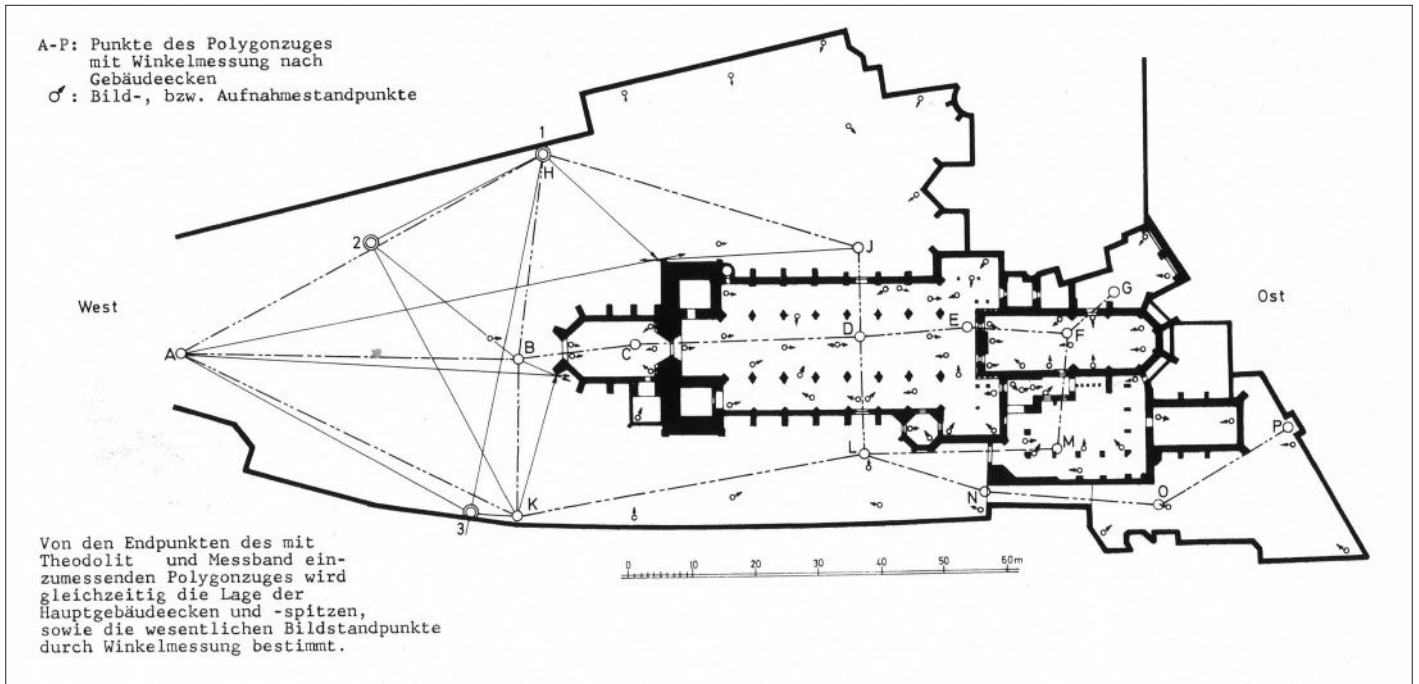

Albrecht Meydenbauer, survey of the Meißener Dom showing the shooting point of photograms 1-3. From Grimm, *op. cit.*, 41.

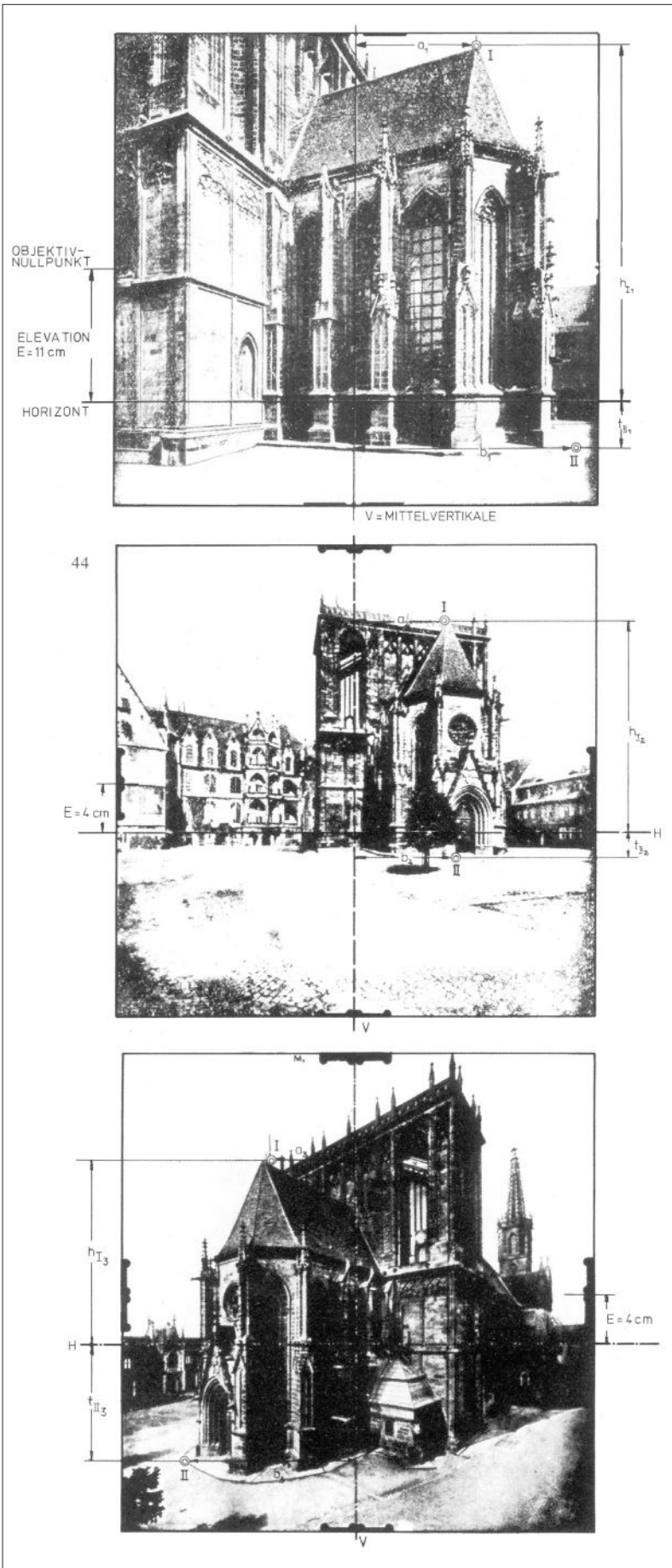

Albrecht Meydenbauer, photographs 1-3 of the Meißener Dom, cross-referenced to Figs 9 and 11. From Grimm, *op. cit.*, 45.

- I = Knauf im Blitzableiter
 II = Bordsteinecke des Traufpflasters
 1, 2, 3 = Bildebenen 1, 2 und 3
 l ⊙ = Bild- bzw. Aufnahmestandpunkt
 K ⊙ = Polygonpunkt
 V = Bildvertikale
 h_{I_1} = Höhe des Punktes I über dem Horizont
 in der Bildebene 1
 t_{II_1} = Tiefe des Punktes II unter dem Horizont
 in der Bildebene 3
 I_1 = Bild des Punktes I in der Bildebene 1
 II_1 = Bild des Punktes II in der Bildebene 1
 a_1 = Abstand
 b_1 = Abstand des Punktes II_1 von der Bildvertikalen

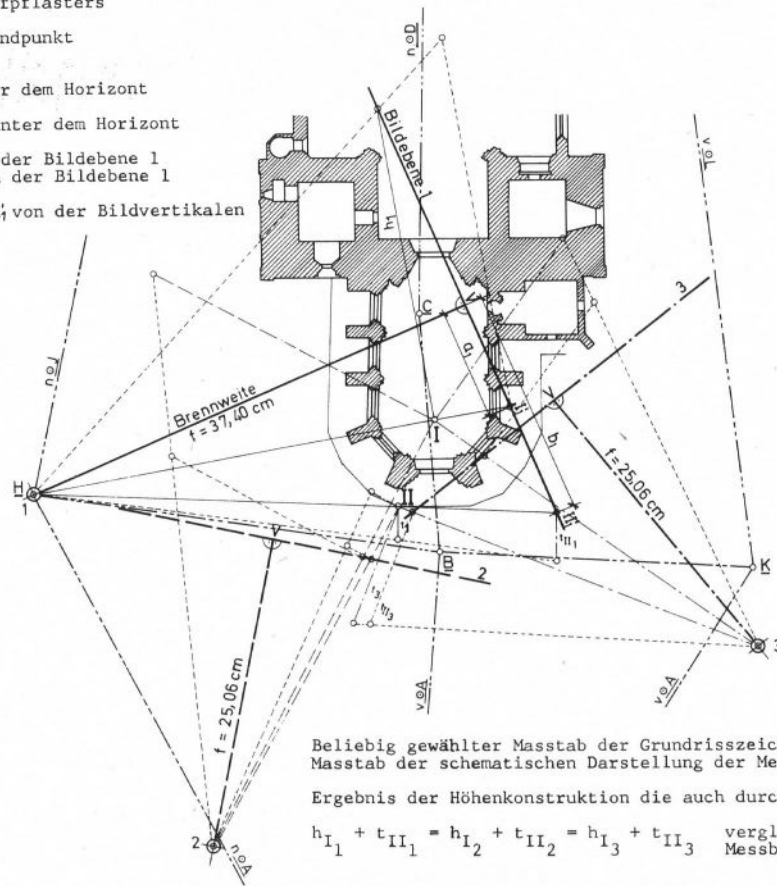

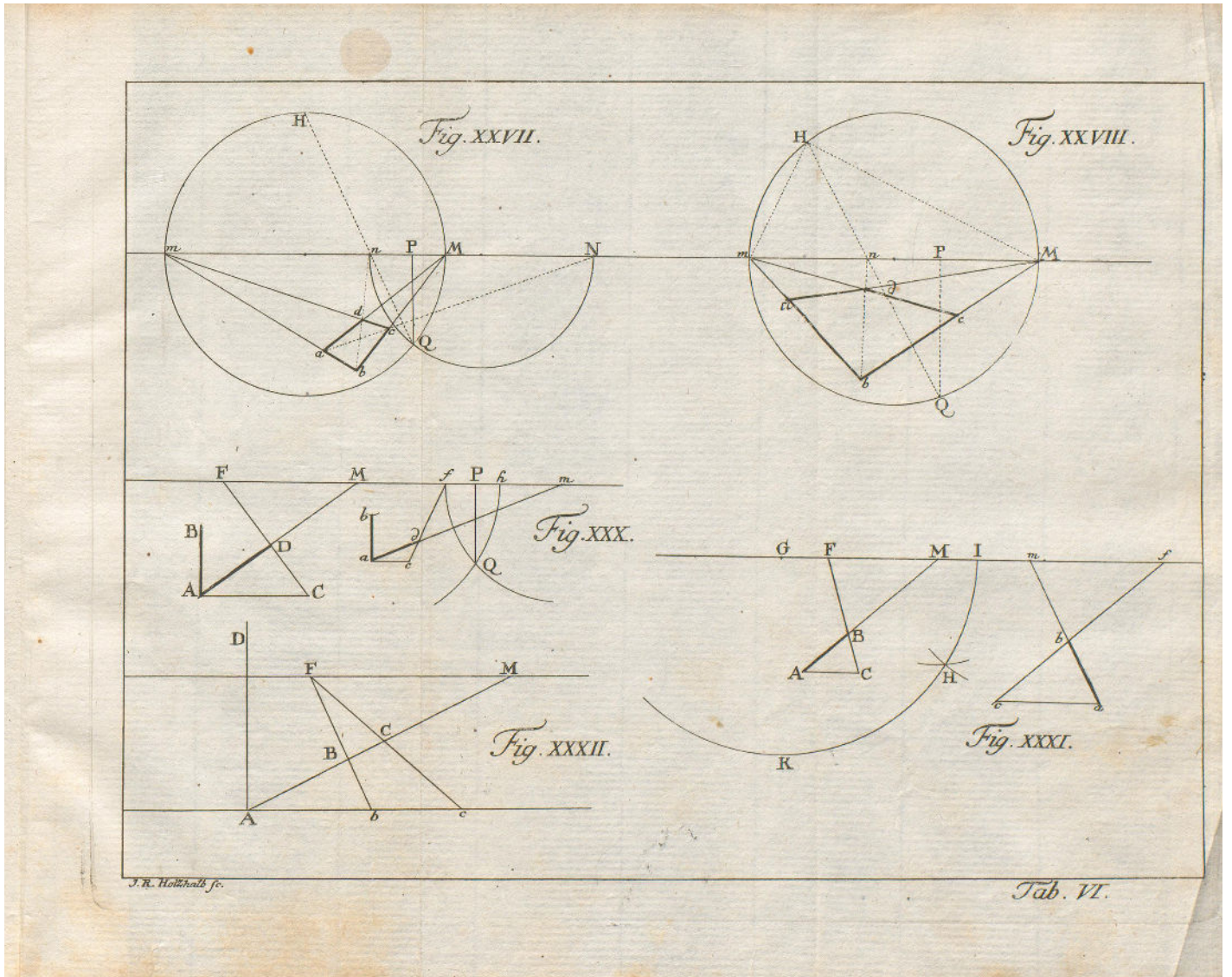

J.H. Lambert, *Die freye Perspective*, plate VI (Zurich, 1759).

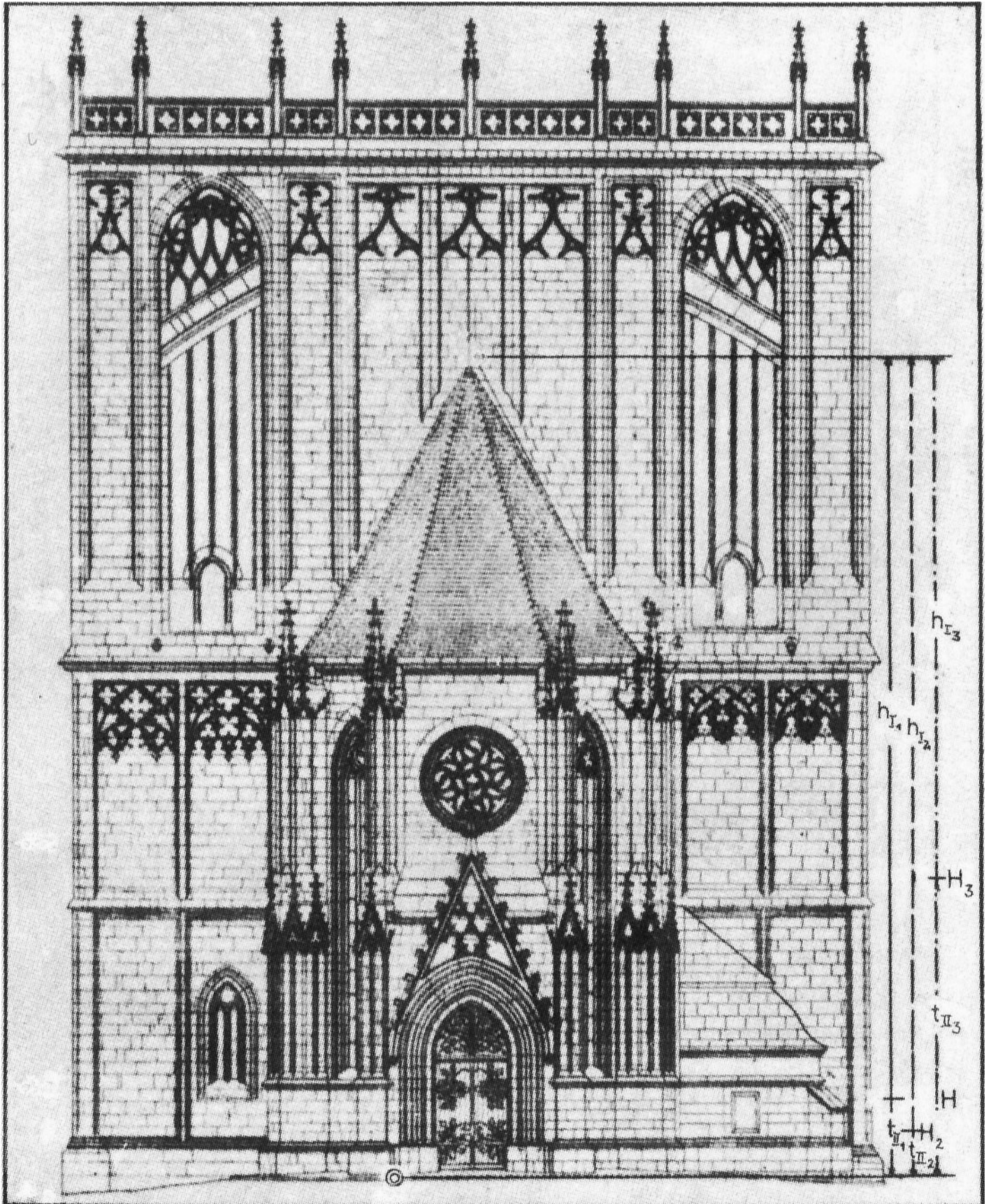

Albrecht Meydenbauer, survey elevation of the west façade of the Meißener Dom, as shown in figs 9–11. From Grimm, *op. cit.*, 46.

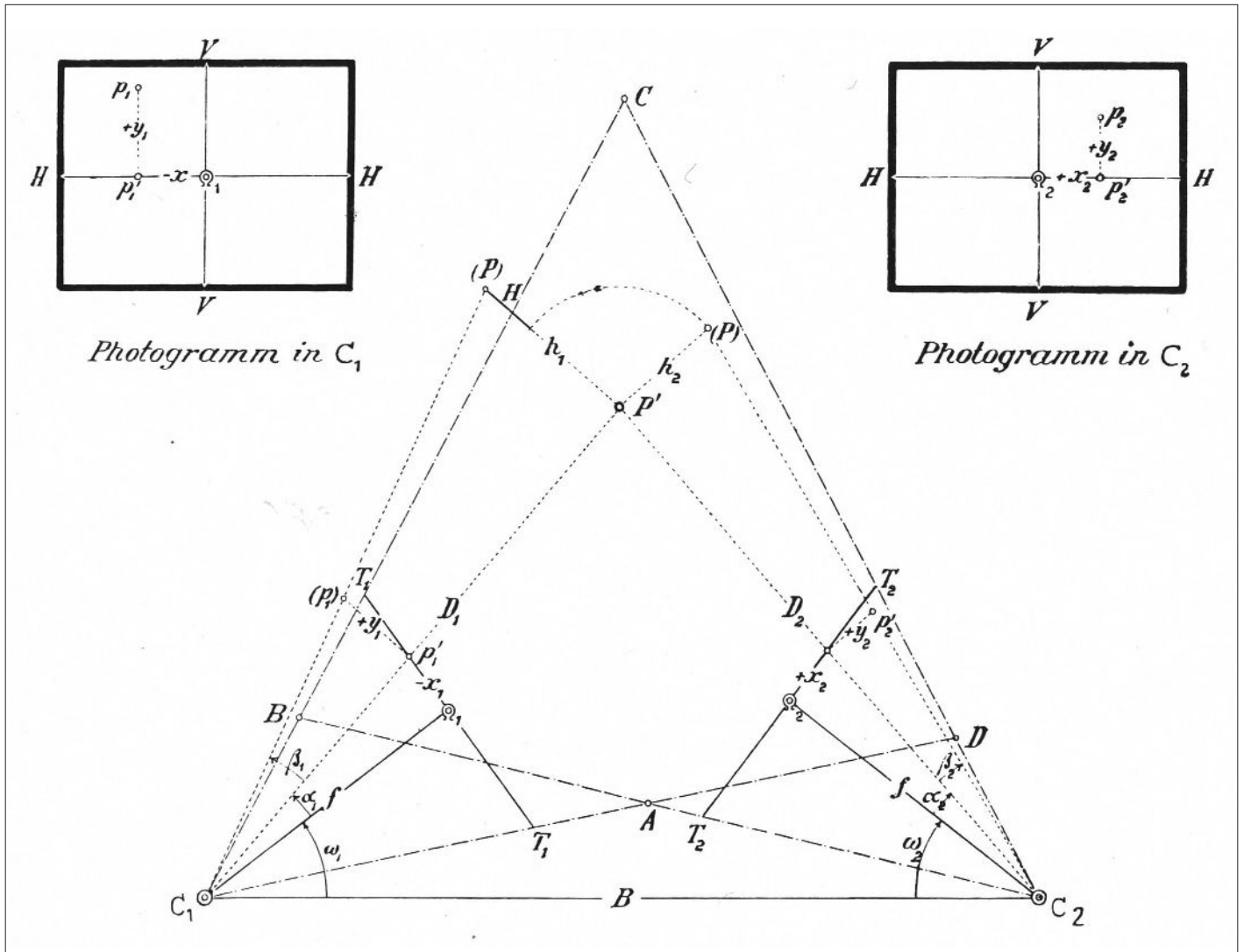

Albrecht Meydenbauer, diagram showing the process of locating a survey point through the correlation of two points on separate picture planes. From Grimm, *op. cit.*, 18.

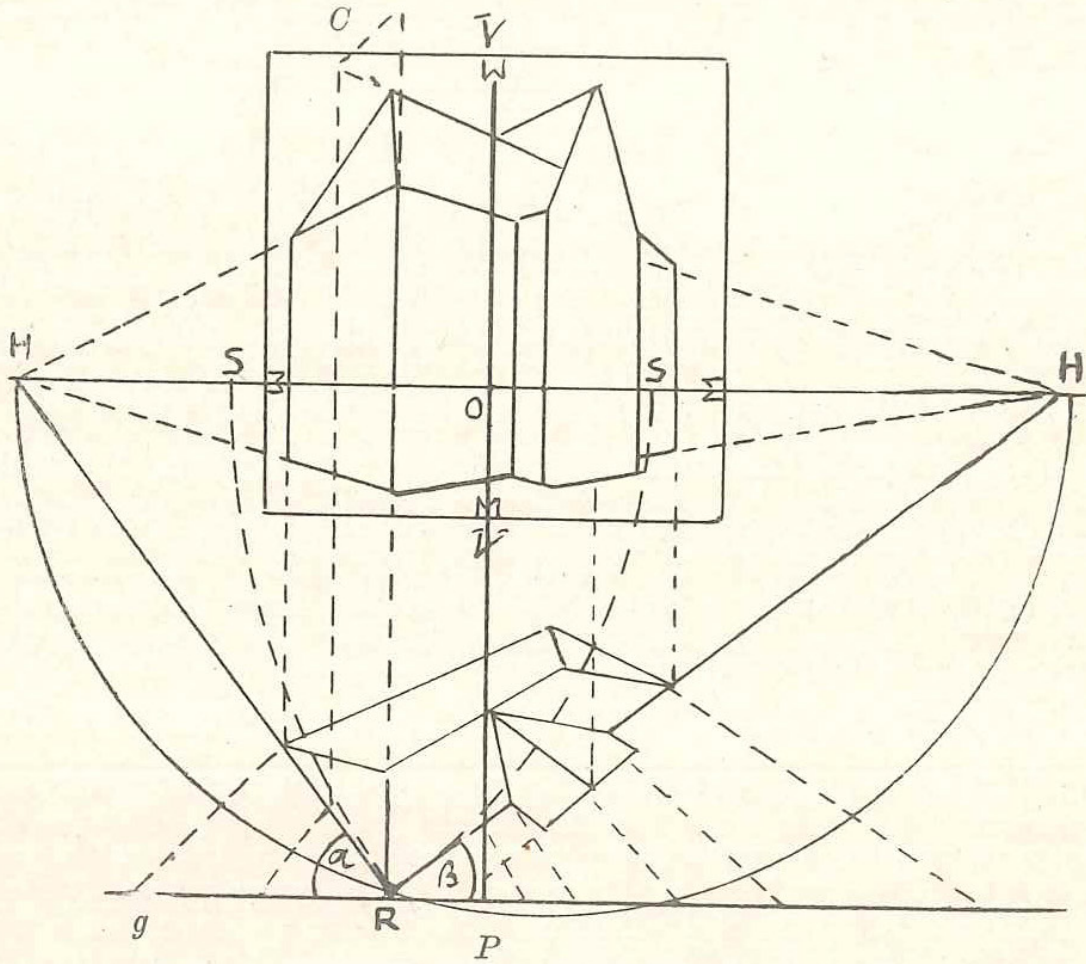
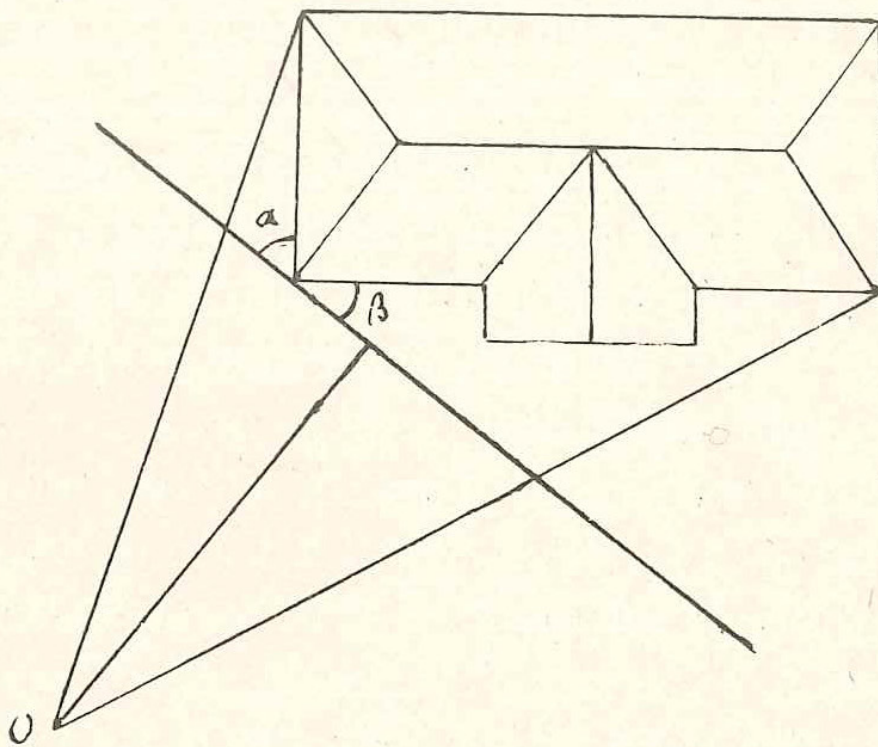
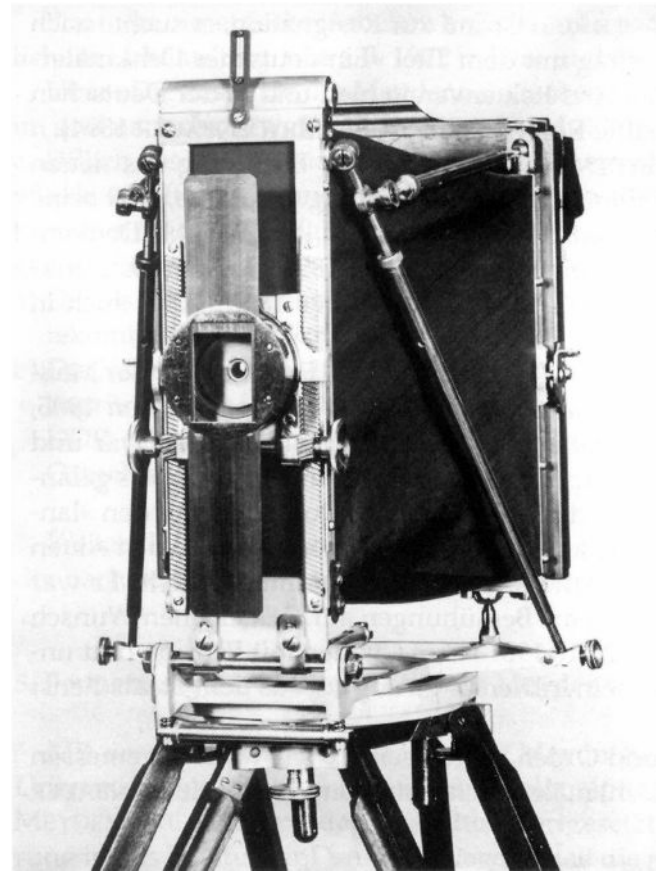
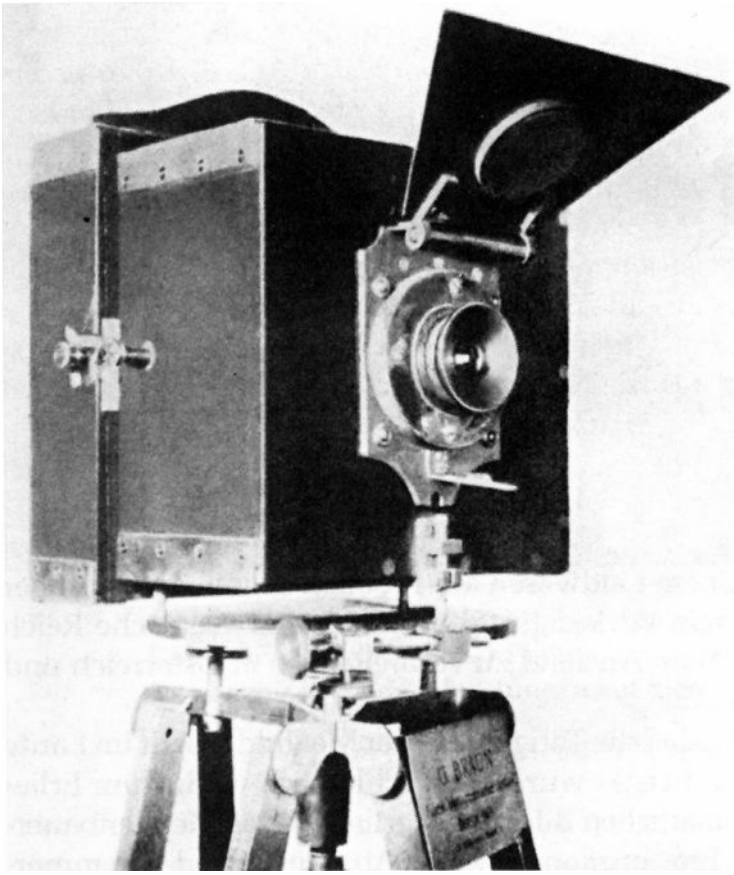

Fig. 85.





Left: The first Meydenbauer *Messbildkamera*, 1864. Right: Meydenbauer's *Messbildkamera*, built after 1890 for easier portability, with format 20 x 20cm. From Albertz and Wiedemann, eds, *Architekturphotogrammetrie*, *op. cit.*, 30, 33.



The workshop of the mechanic Benndorf, constructing *Messbildkamas* in Meydenbauer's Messbildanstalt, Breitestrasse 36/37, Marstallgebäude, c.1934. Brandenburg State Office for the Preservation of Historical Monuments and Archaeological Museum.

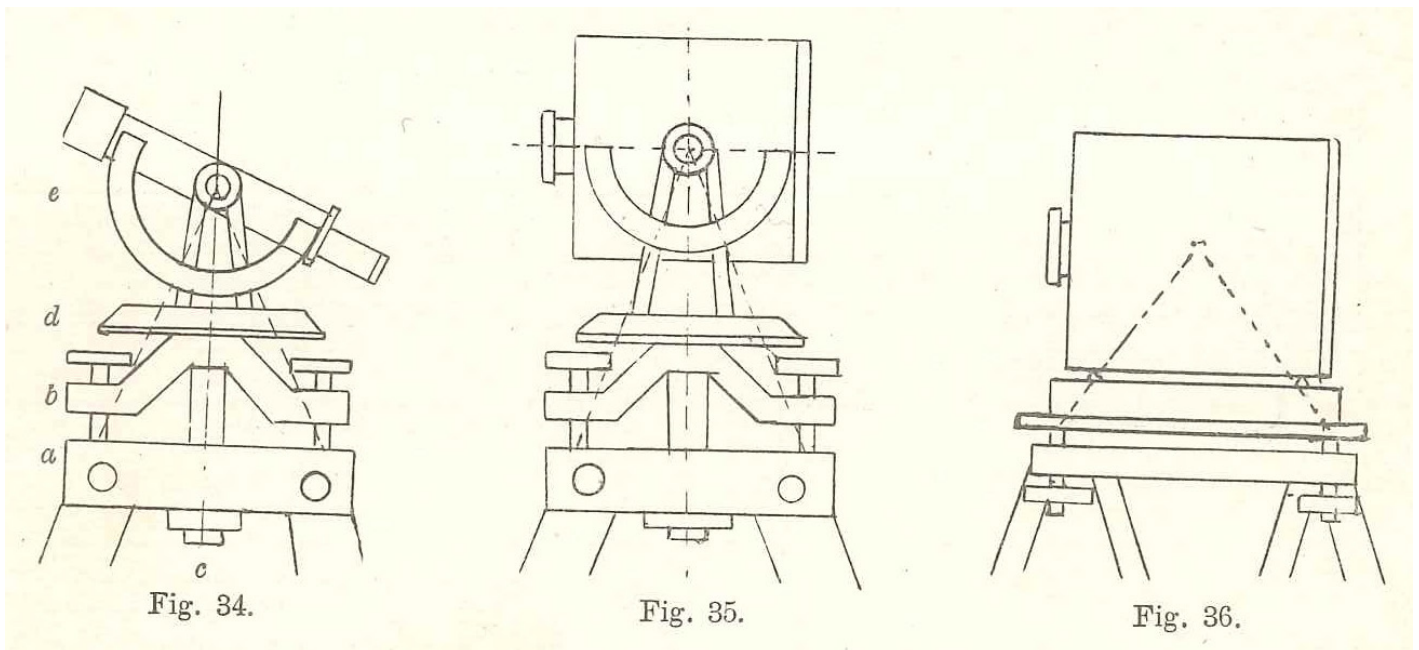
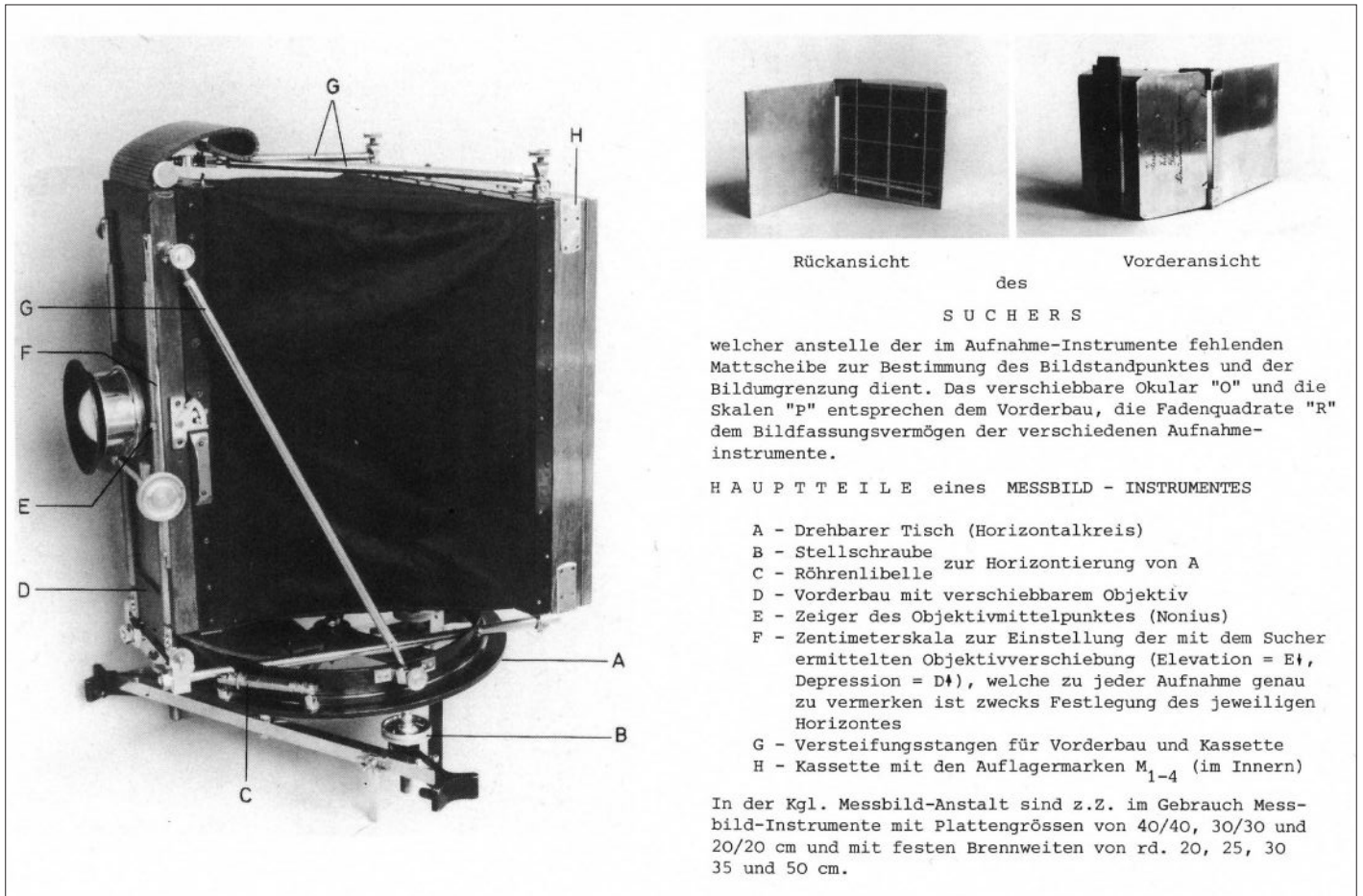

19— Albrecht Meydenbauer, an explanation of the *Messbildkamera*. From Grimm, *op. cit.*, 42.

20— Albrecht Meydenbauer's mounting system for the *Messbildkamera* (shown on far right).
From Meydenbauer, *Handbuch*, *op. cit.*, 77.



Messbild archive, with storage system designed by Meydenbauer, in the Staatliche Bildstelle Berlin, Marstallgebäude, 1935. Brandenburg State Office for the Preservation of Historical Monuments and Archaeological Museum.



The return of the Meydenbauer archive from the Architecture Museum of the USSR Academy of Architecture and Construction in Moscow to the Berlin State Museums, Berlin, 1959. Brandenburg State Office for the Preservation of Historical Monuments and Archaeological Museum.

2. 4 | |

Berlin, Hauptstadt der DDR
Franzoesischer Dom

(DDR)

1882



Verfilmung des Meydenbauerschen Meßbildarchivs 1981 – Verkleinerung vom Original 40×40 cm²

Albrecht Meydenbauer, photogram of the French Church in Berlin, 1882 (reconstructed 1977 on the basis of Meydenbauer's photographic survey). Original 40 x 40 cm. Brandenburg State Office for the Preservation of Historical Monuments and Archaeological Museum.